

SERIES 850 LINEAR

AVAILABLE WITH EITHER SPADE OR BULL NOSE END CAPS



SPADE

BULL NOSE

Application

- Open office ambient lighting for virtually glare free and shadow free illumination.

Finishes

- Bare 20 gauge roll formed steel housing in solid or perforated patterns.

Reflectors:

- Enhanced anodized aluminum with over 95% reflectance. It is shipped as an assembly with lamp holder brackets and adjustable ballast brackets attached. Reflector is slotted when used with the perforated housing. Unit is shipped with bracket that accepts 1, 2 or 3 lamp holders as standard.

Features

- Units are shipped with die cast aluminum joiners installed for suspension and structural continuity.
- Designed to mount on exact 4 foot and 8 foot centers. Joiners will accept stems, single cable, "V" cable and power cords as supplied by lighting fixture manufacturer.
- A computer designed optical system that maximizes the output of T5 and T5HO lamps (1, 2 or 3) producing very wide distribution for even ceiling brightness with mounting from 12 to 18 inches from the ceiling. Efficiencies exceed 96% at 25 degree C ambient and over 100% at 35 degree C ambient.
- Architectural ends. There are two die cast aluminum designs available, "spade" and "bullnose" configurations. They are bolted to the die cast joiners for a complete architectural look.

Optional Features

- The housings are roll formed which allows custom lengths with predictable results. Units could also be used in a wall mounted version. Please contact factory for any optional feature.

Custom modifications in the physical specification and color are available for this fixture.

Lamping Options

T5
(1-3) 54W (4')
(2-6) 54W (8')

Packaging

Bodies per skid	4'	8'
	50	50



SERIES 850 LINEAR

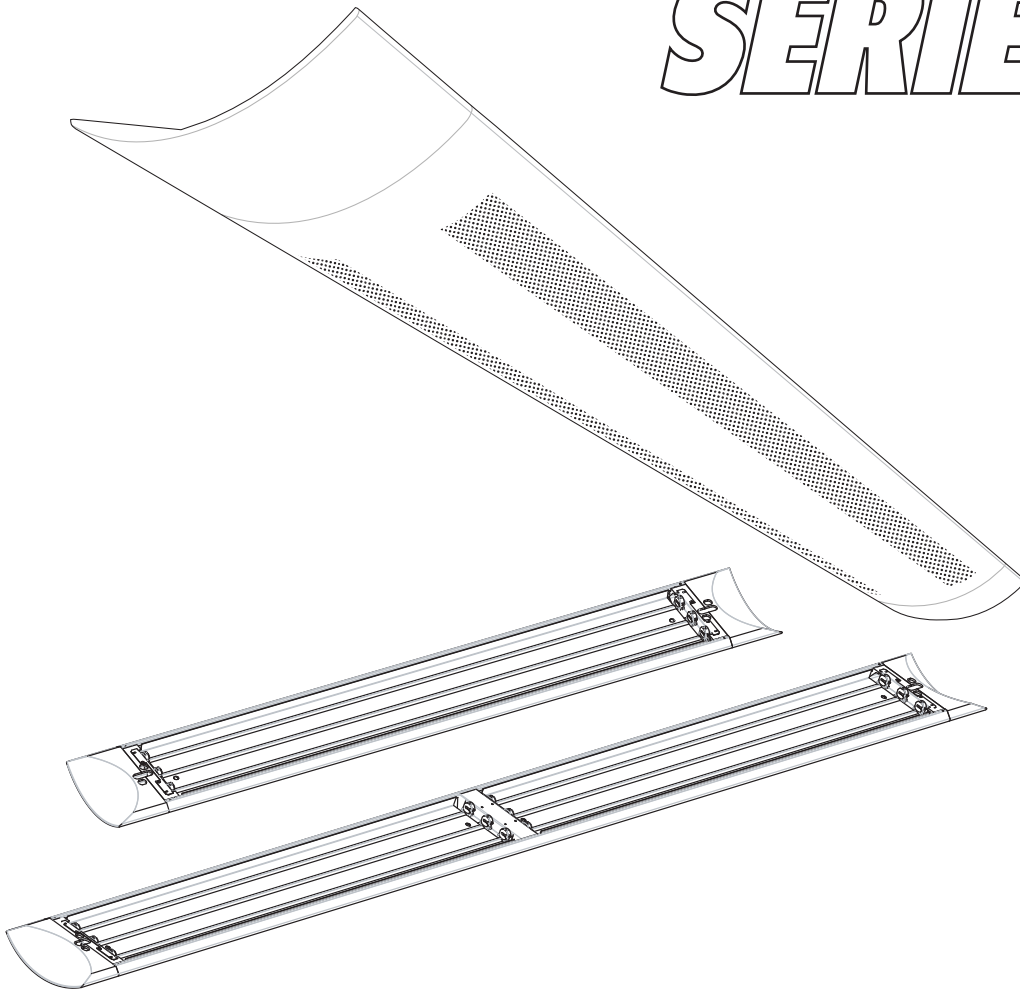

AVAILABLE WITH
EITHER SPADE OR
BULL NOSE
END CAPS

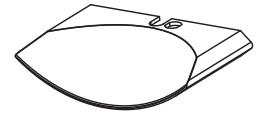

SPADE

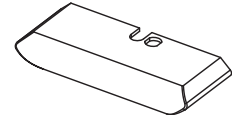

BULL NOSE

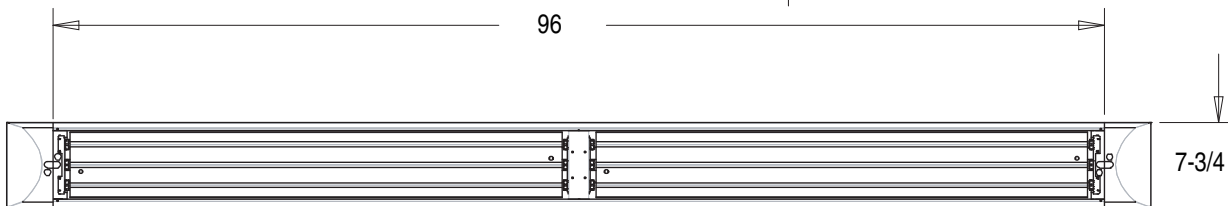

T5	
SIZE	LENGTH
(1 to 3) 54W	48
(2 to 6) 54W	96

Add 3" for each Bull Nose end cap
Add 4-1/4" for each Spade end cap

REV 7-27-09



PAINING PROCEDURES FOR SUSPENDED & WALL MOUNT LINEAR FIXTURES

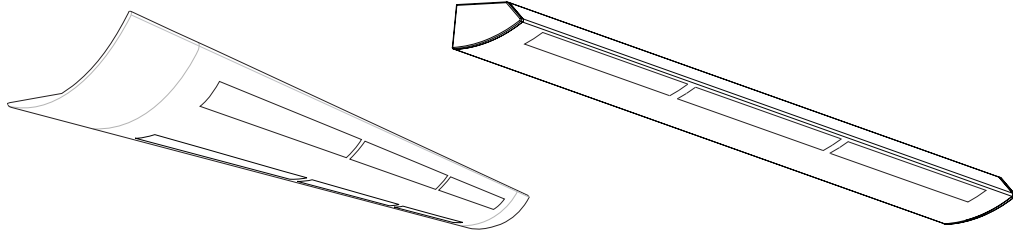

SEND THESE PROCEDURES WITH FIXTURES TO THE PAINTER

PROCEDURES:

1. Make sure end caps are mounted to the body before painting.
2. If no end caps are needed, make sure you mask off the outside face of the joiner before painting. This will assure a good fit between joiners.
3. Make sure the painter is aware that the body is steel and the end cap and joiner are aluminum cast.
4. The painter should check the gap between the end cap and joiner to make sure there is a good fit and that there are no gaps before painting. Close gaps by pushing the end cap towards the body.



4 FT ASSEMBLY

HARDWARE LIST (by other)

- (A) 8-32 X 1/4" Long Self Tapping Screw (4 Pcs.)
"Do not replace with SHEETMETAL SCREWS"
- (B) 1/4-20 X 1 3/4" Long Hex Head (4 Pcs.)
- (C) 1/4 TURN FASTENER (2 Pcs.) / Supplied

ASSEMBLY INSTRUCTIONS

- 1.) Mount End Caps to Body with (B).
- 2.) Install Ballast Assembly with (A).
- 3.) Install Reflector with (C)
- 4.) Peel off protective coating on reflector.

NOTE:

If running continuous string of bodies, connect bodies together with (B) to each Joiner. At the end of run mount End Cap. Make sure each Joiner has a suspension system.

All suspension systems to be supplied by others.

Warning:

Each Joiner must have a suspension system.

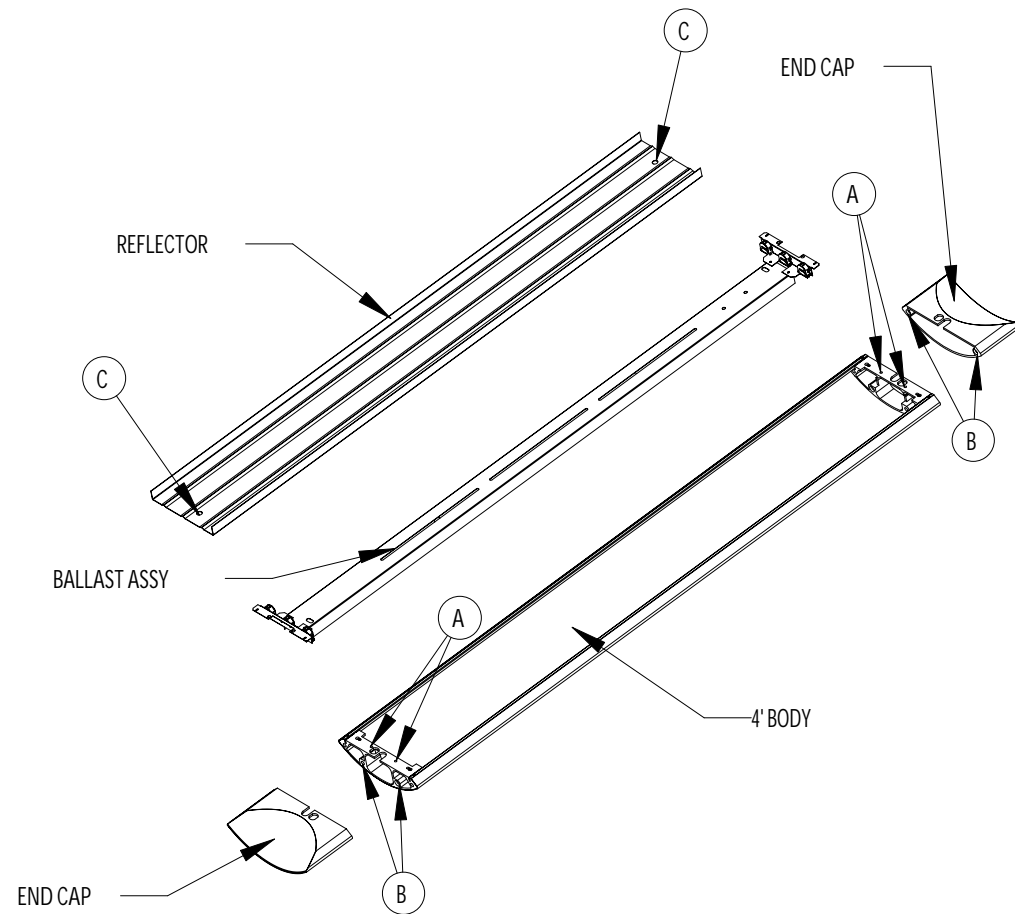

NOTE:

When attaching the Bodies together use the bottom holes on the Joiner.





HARDWARE LIST (by other)

- (A) 8-32 X 1/4" Long Self Tapping Screw (4 Pcs.)
- (B) 1/4-20 X 1 3/4" Long Hex Head (4 Pcs.)
- (C) 8-32 X 1/4" Long Sheetmetal Screw (4 Pcs.)
- (D) 1/4 Turn Fastener (4 Pcs.) / Supplied

8 FT ASSEMBLY

ASSEMBLY INSTRUCTIONS

- 1.) Mount End Caps to Body with (B).
- 2.) Insert Center Plate in the Body. (Snaps in place)
- 3.) Install Ballast Assemblies with (A)
- "DO NOT USE SHEET METAL SCREWS"
- 4.) Install Reflector with (D).
- 5.) Peel off protective coating on reflector.

NOTE:

If running continuous string of bodies, connect bodies together with (B) to each Joiner. At the end of run mount End Cap. Make sure each Joiner has a suspension system.

All suspension systems to be supplied by others.

Warning:

Each Joiner must have a suspension system.

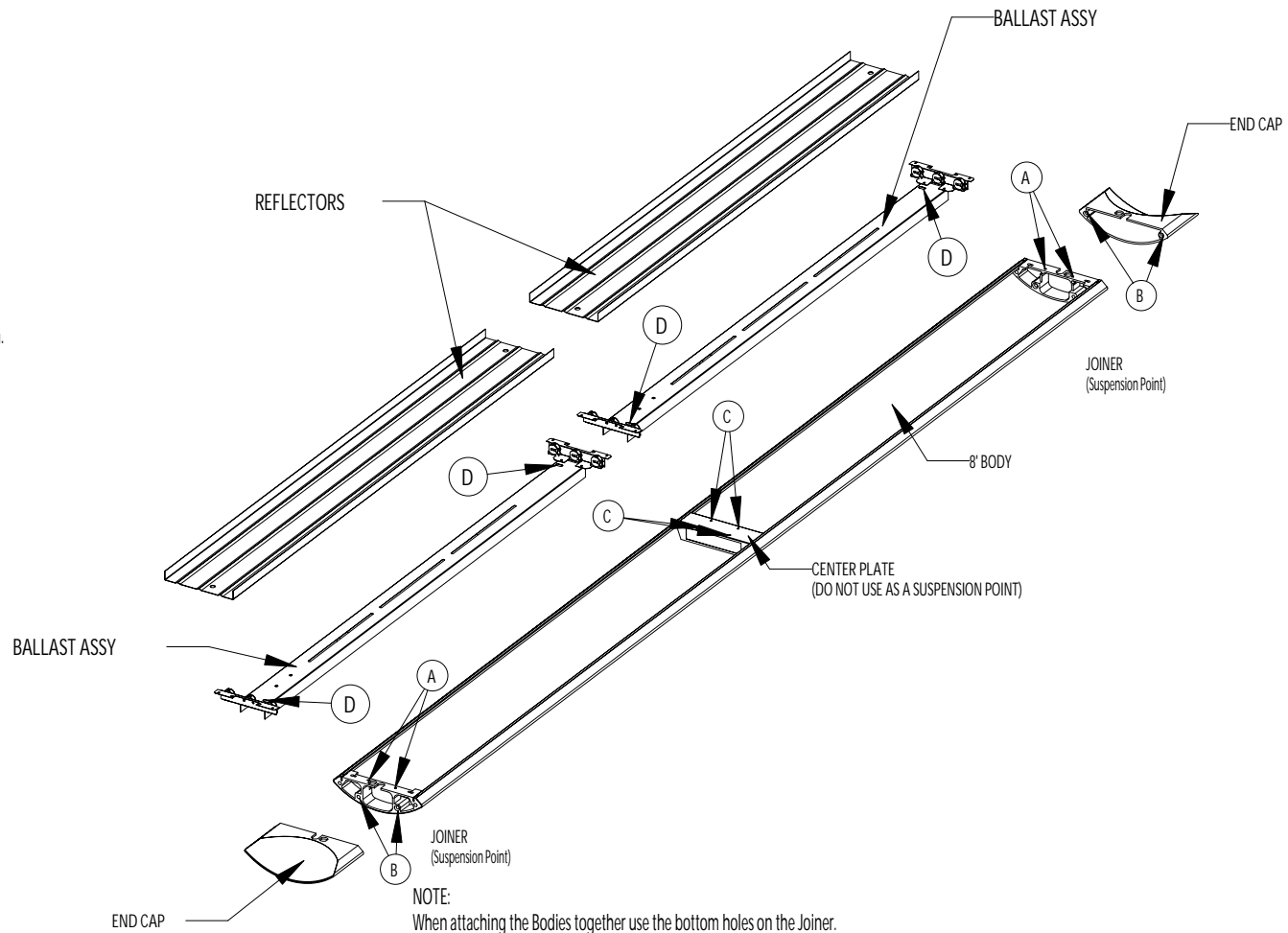

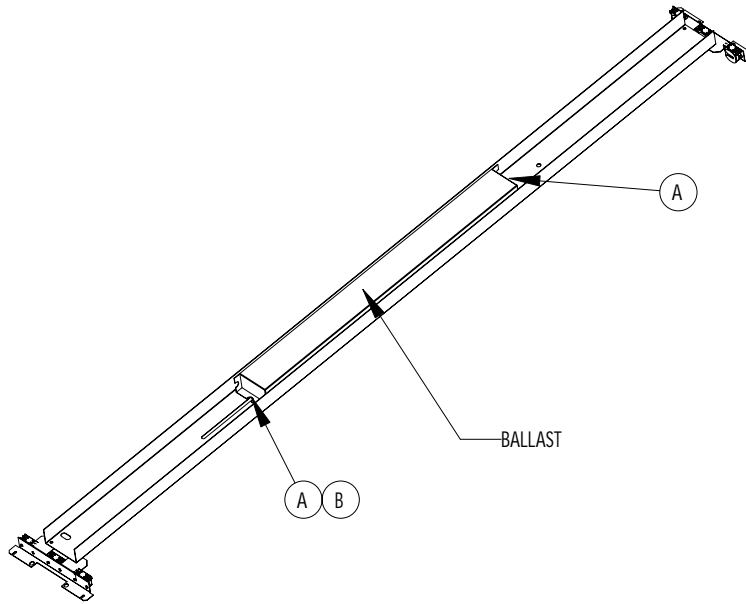

BALLAST ASSEMBLY

ASSEMBLY INSTRUCTIONS

- 1.) Attach Ballast to the 8-32 Stud provided in the Wire Trough with 8-32 Lock Nut.
- 2.) Attach other end of Ballast to the slot provided in the Wire Trough with 8-32 Screw & Lock Nut.
- 3.) Snap in Lamp Holders to the bracket, use standard at one end and spring back at the other end.

HARDWARE LIST (by other)
(A) 8-32 Capped Washer Type Lock Nut (3 PCS)
(Palnut Company Cat.# DO832075)
(B) 8-32 X 3/8" Long Screw

RECOMMENDED SOCKETS

(3 Pcs - 600V Rotary G5)
Vossloh Schwabe - 108663
Stucchi - 285/FAU
BJB - 26.641.2001.50
ALP - LH-150-28

(3 Pcs - 600V Rotary G5 Spring)
Vossloh Schwabe - 108664
Stucchi - 285/MAU
BJB - 26.641.2007.50
ALP - LH-150-28S

